

SCHOTT® HeliIntense Spectrum^{CC}

Fully brightness and color stabilized LED light source, providing high light output



Recommended Applications

Edge or contour lighting in seats or monuments realized with one light source and SCHOTT® HeliLine.

Functional cabin lighting realized as spot or line lights with SCHOTT® HeliLine, HeliFlex and HeliRod.

Homogeneous mood lighting realized with SCHOTT® HeliLine, HeliFlex or HeliRod.

Product Characteristics

The SCHOTT® HeliIntense Spectrum^{CC} light source is an efficient and very strong LED light source that was developed specifically to combine SCHOTT's expertise in fiber optics with LED technology to provide customized and ultimate cabin lighting.

Compared to the SCHOTT® HeliIntense single color, it features full color capability and color as well as brightness control with a true color sensor. This guarantees stability of color and brightness in between all cabin applications and over the whole lifetime of the light source.

Technical Specifications

Power input	12-28 VDC (power supply)
Power consumption	max. 10 W (depending on color setting)
Control	RS-485, SCHOTT standard protocol Customization on request
Control features	On / Off / Dimming (0,5...100%) / Color change
Connector	HD SUB-D
Color	RGBW, color gamut: R: 0.675/0.305 G: 0.200/0.650 B: 0.165/0.045 Colour consistency < 3 SDCM
Address selection	Daisy chain concept
Weight	180 g
Luminous flux (white light, 4000K)	max. 60 lm (without lightguide)
Qualification	DO-160 G

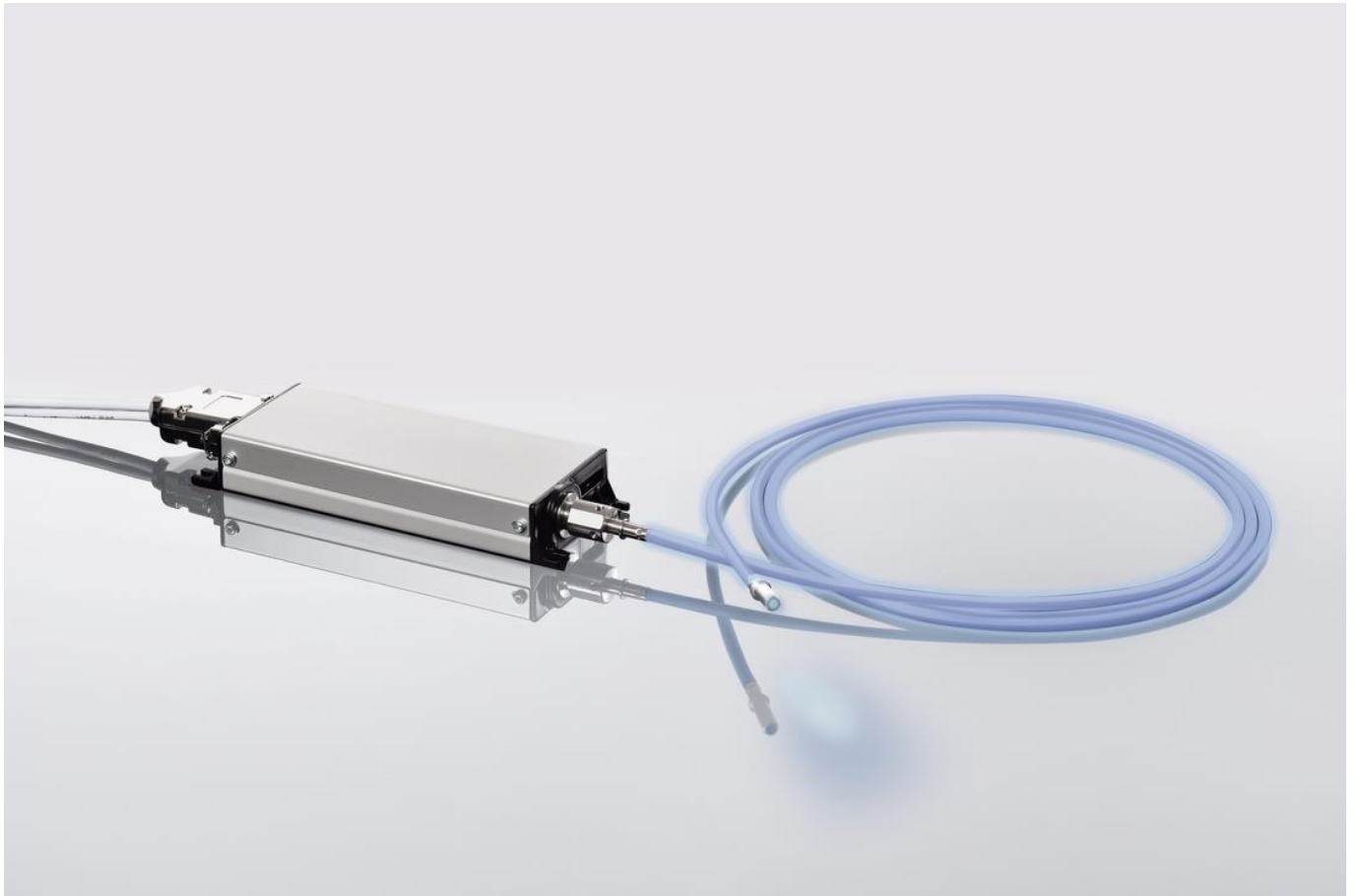

Strong and efficient LED light source providing full range of stable colors

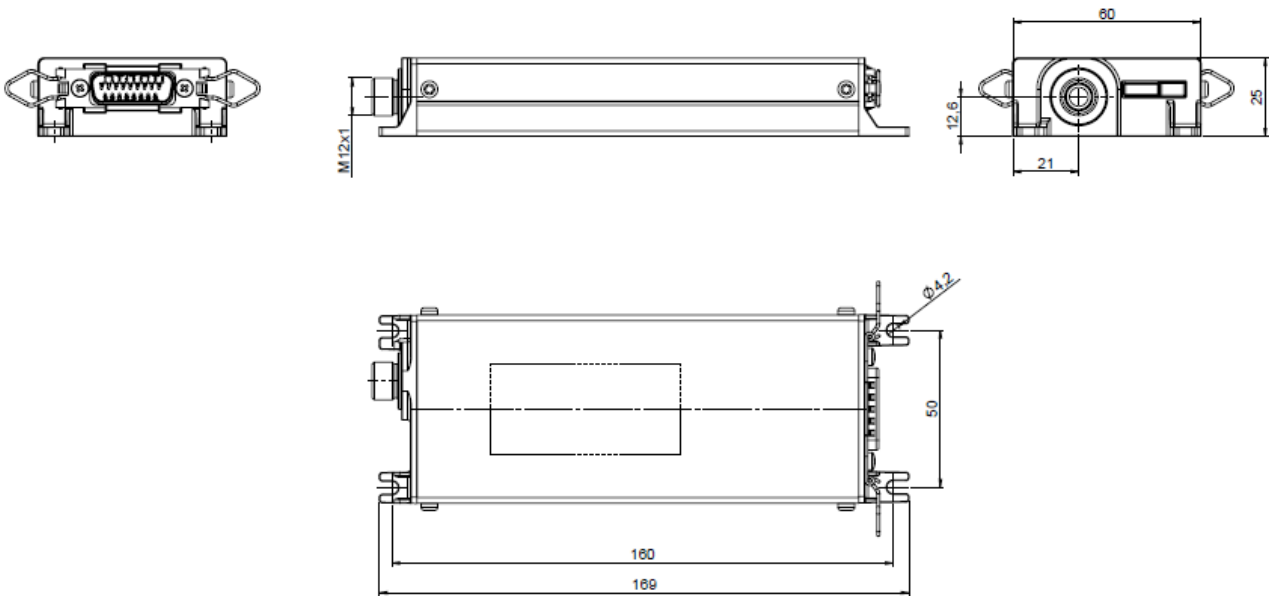

All specifications are subject to change without prior notice. This datasheet or any extracts thereof may only be used in other publications with express permission of SCHOTT. © SCHOTT AG

Lighting and Imaging
SCHOTT AG
 Hattenbergstrasse 10
 55122 Mainz
 Germany
 Phone: +49 (0) 6131/66-7914
 Fax: +49 (0) 6131/66-7850
 lightingimaging@schott.com
 www.schott.com/lightingimaging

